

ACCESSORIES FOR GREASE PUMPS

Drum cover for pumps with suction tube \varnothing 45



P/N OE10/50

Drum cover \varnothing 600 mm

► drums external \varnothing 550 - 600 mm

P/N OE10/51

Drum cover \varnothing 420 mm

► drums external \varnothing 370 - 420 mm

P/N OE10/52

Drum cover \varnothing 385 mm

► drums external \varnothing 340 - 385 mm

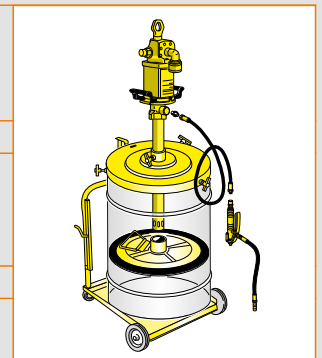

Drum cover for pumps with suction tube \varnothing 50,8



P/N OE10/55

Drum cover \varnothing 600 mm

► drums external \varnothing 550 - 600 mm

P/N OE10/56

Drum cover \varnothing 420 mm

► drums external \varnothing 370 - 420 mm

P/N OE10/57

Drum cover \varnothing 385 mm

► drums external \varnothing 340 - 385 mm

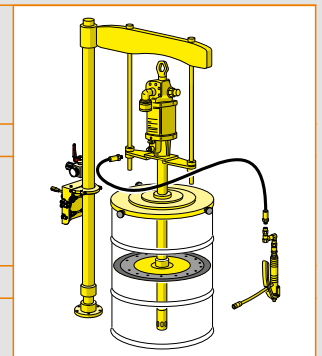

Drum cover with 2" F union suitable for standard bung adaptor

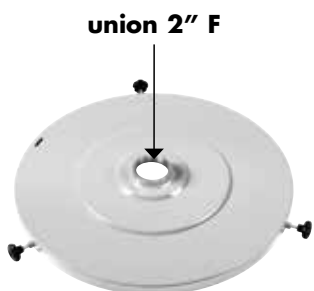

P/N OE65160

Drum cover \varnothing 600 mm

► drums external \varnothing 550 - 600 mm

P/N OE65142

Drum cover \varnothing 420 mm

► drums external \varnothing 370 - 420 mm

P/N OE65138

Drum cover \varnothing 385 mm

► drums external \varnothing 340 - 385 mm

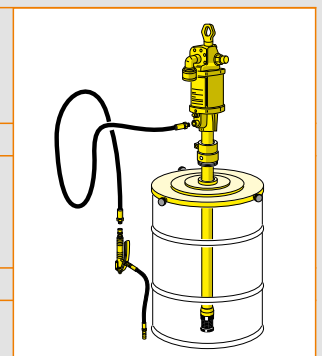

P/N OE66599

Handle for portable grease kit supplied with grease kits P/N OE64021 - P/N OE64031